

Assembly guide

TABLE TORO

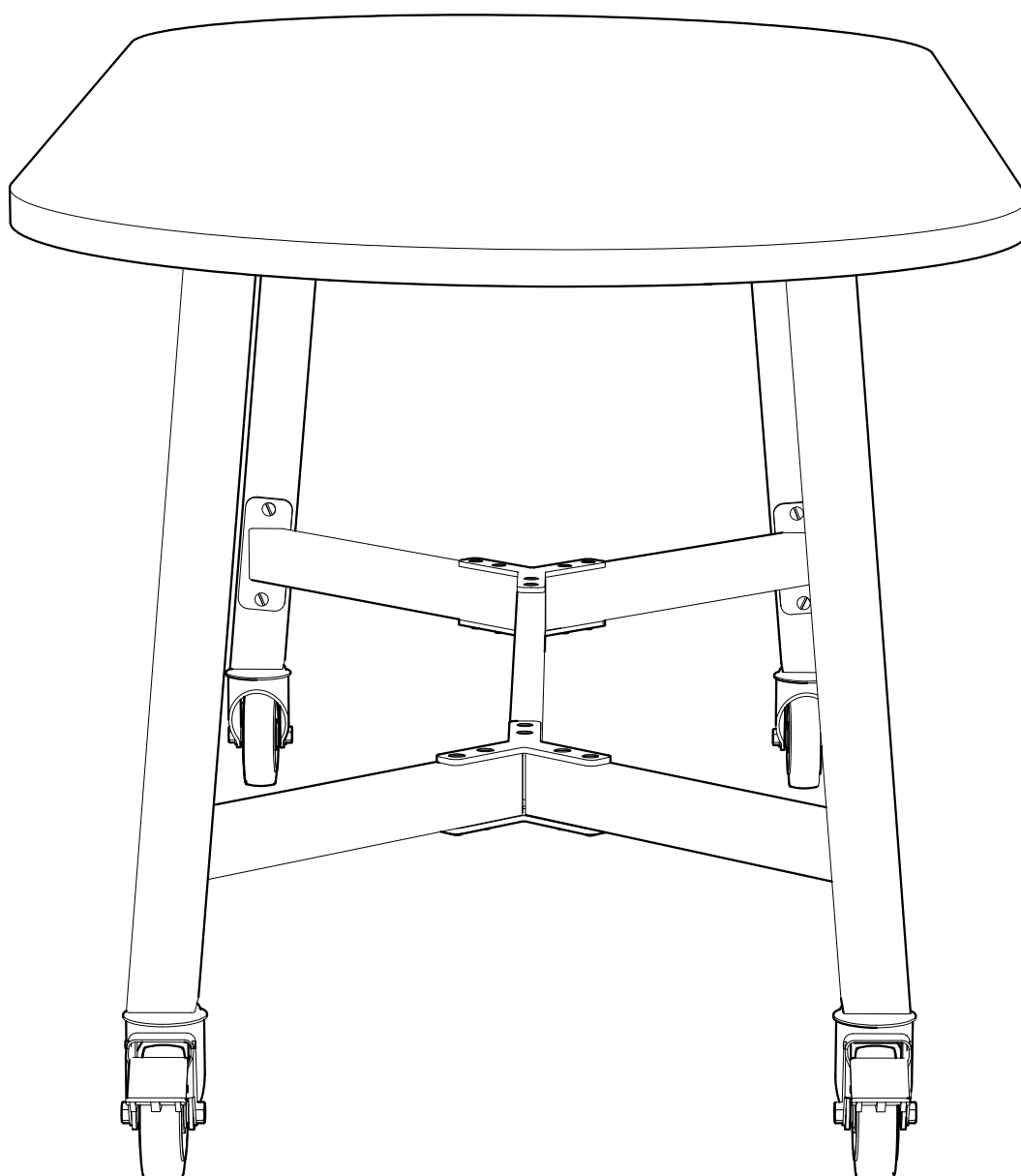

Assembly instructions

TTCX-XXXX / TTRX-XXXX / TTOX-XXXX

STEP 1

Turn the table top upside down and place it on the floor. Secure the legs with round-head screws, ensuring that the notch on the leg plate faces away from the table.

IMPORTANT:

Leave the screws slightly loose.

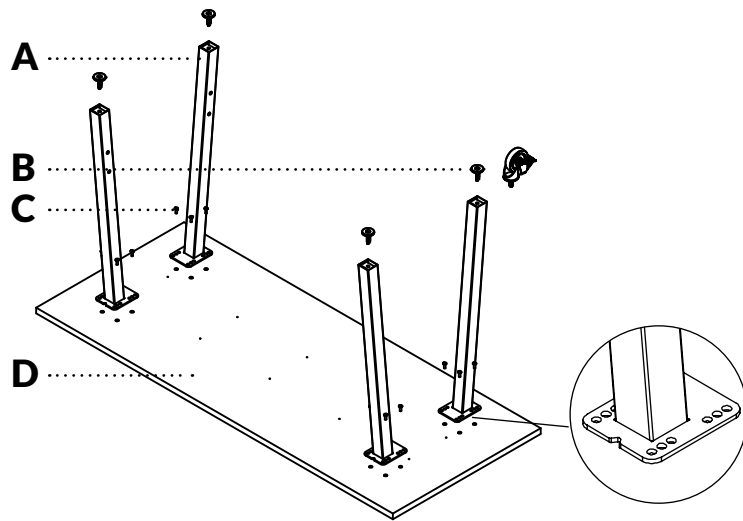

Positioning of screws according to table height

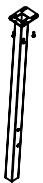
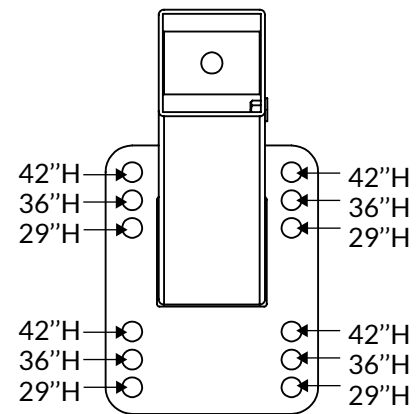

A 4 x leg



B 4 x leveler or caster



C 16 x black round-head screw

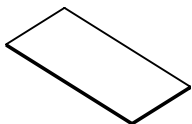

D 1 x table top

Assembly instructions

TTCX-XXXX / TTRX-XXXX / TTOX-XXXX

STEP 2

Screw in the angled crosspieces using the black flat-head screws.

IMPORTANT:

Leave the screws slightly loose.

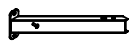
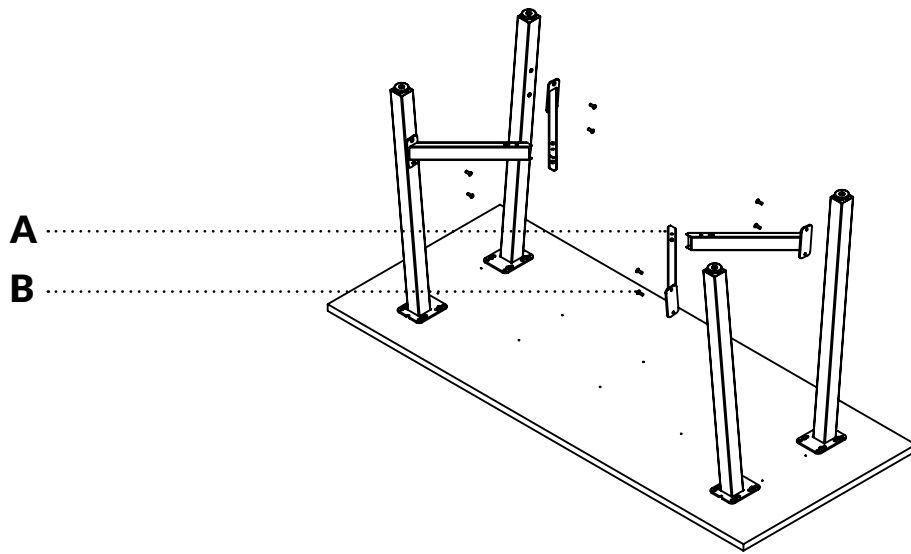

A 4 x angled crosspiece



B 8 x flat-head screw

Assembly instructions

TTCX-XXXX / TTRX-XXXX / TTOX-XXXX

STEP 3

Use the flat-head screws to secure the «Y» plates on both pairs of legs.

IMPORTANT:

Leave the screws slightly loose.

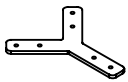
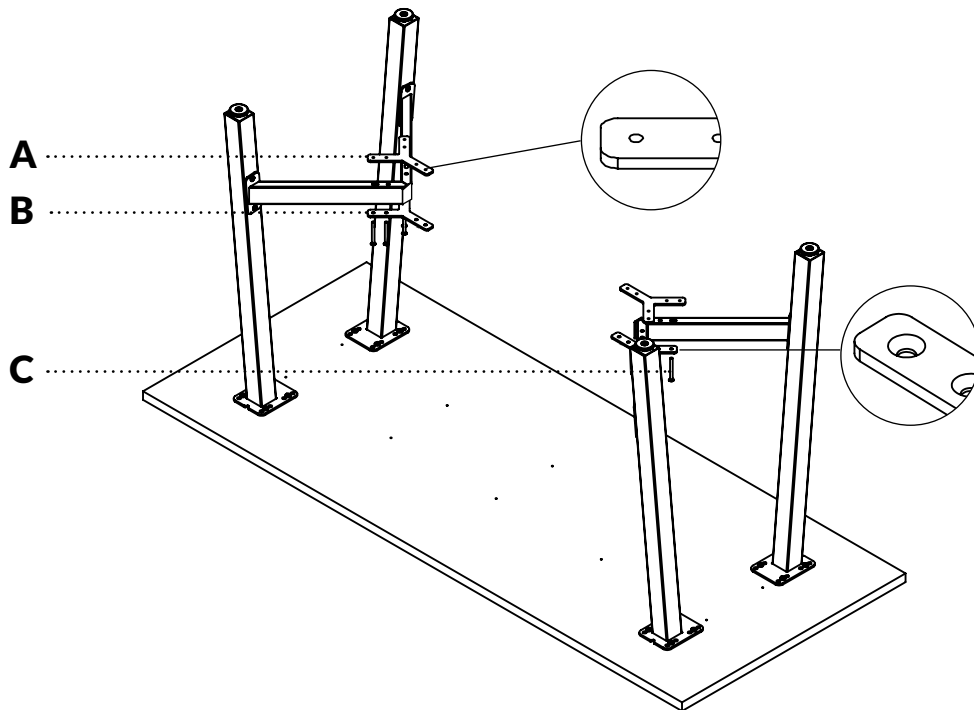

A 2 x lower «Y» plate

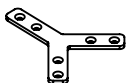

B 2 x upper «Y» plate



C 8 x flat-head screw

Assembly instructions

TTCX-XXXX / TTRX-XXXX / TTOX-XXXX

TORO

STEP 4

Fix the horizontal crosspiece between the 4 «Y» plates.

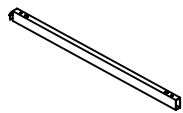
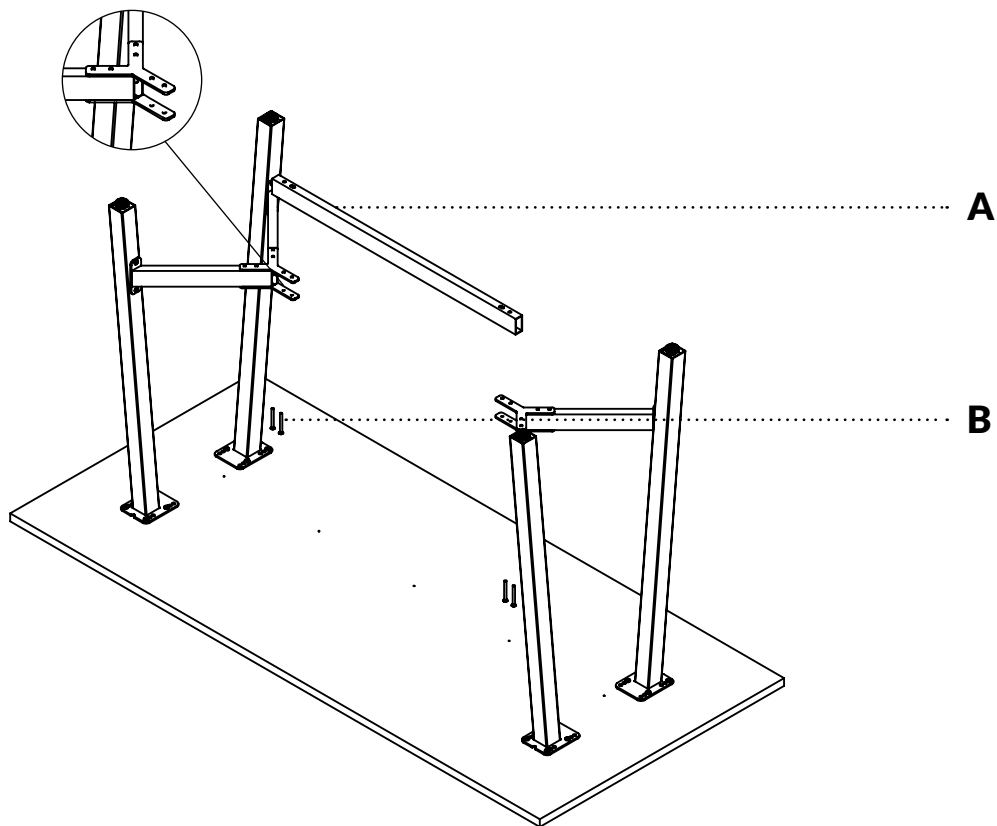

A 1 x horizontal crosspiece



B 4 x flat-head screw

Assembly instructions

TTCX-XXXX / TTRX-XXXX / TTOX-XXXX

STEP 6 (72" L table top and over)

Install the reinforcing bars under the surface using the wood screws. Use the pre-drilled holes as a guide during installation.

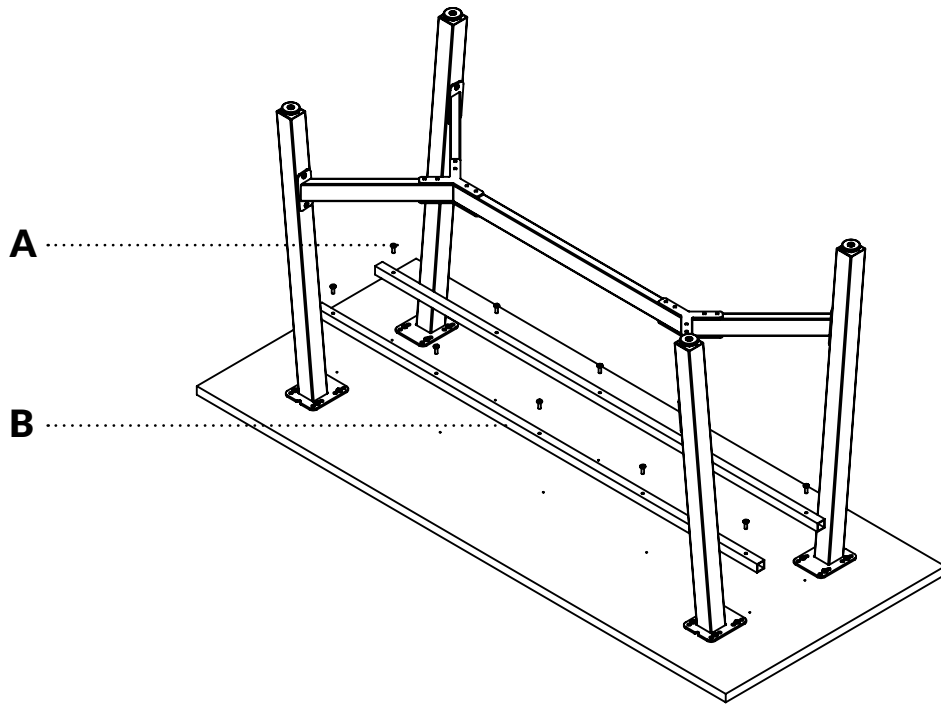

A 10 x wood screw

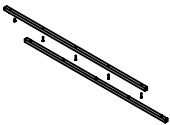

B 2 x barre de renforcement

Assembly instructions

TTCX-XXXX / TTRX-XXXX / TTOX-XXXX

TORO

STEP 7

Tighten all screws firmly and turn the assembled table over.

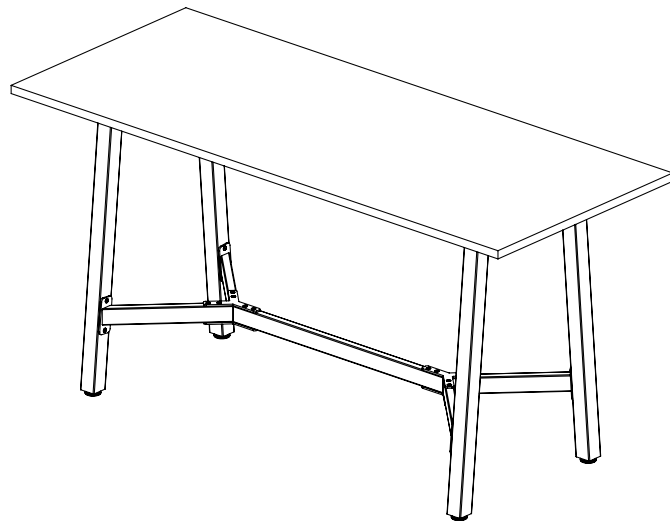
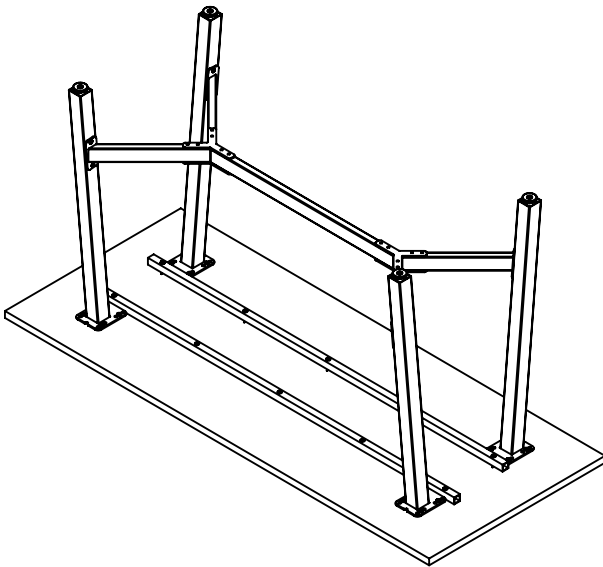

Assembly instructions

TTCX-XXXX / TTRX-XXXX / TTOX-XXXX

STEP 8 (electrical module installation)

Install the reinforcing bars under the surface using the wood screws. Use the pre-drilled holes as a guide during installation.

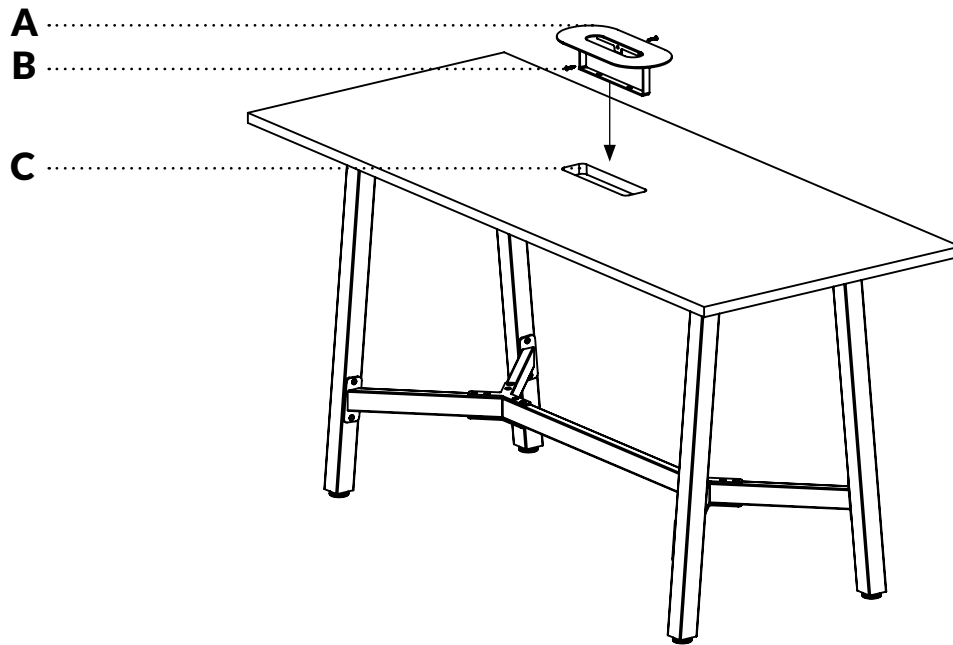

A 2 x wood screw



B 1 x electrical module support

C 1 x surface hole for electrical module

Assembly instructions

TTCX-XXXX-XXH-CDT / TTRX-XXXX-XXH-CDT / TTOX-XXXX-XXH-CDT

STEP 9

Remove the screws at the back of the electrical module. Slide the module into the bracket and secure it with the screws you removed. Insert the screws into each of the black plastic washers supplied, then finish installing the module.

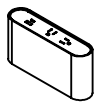
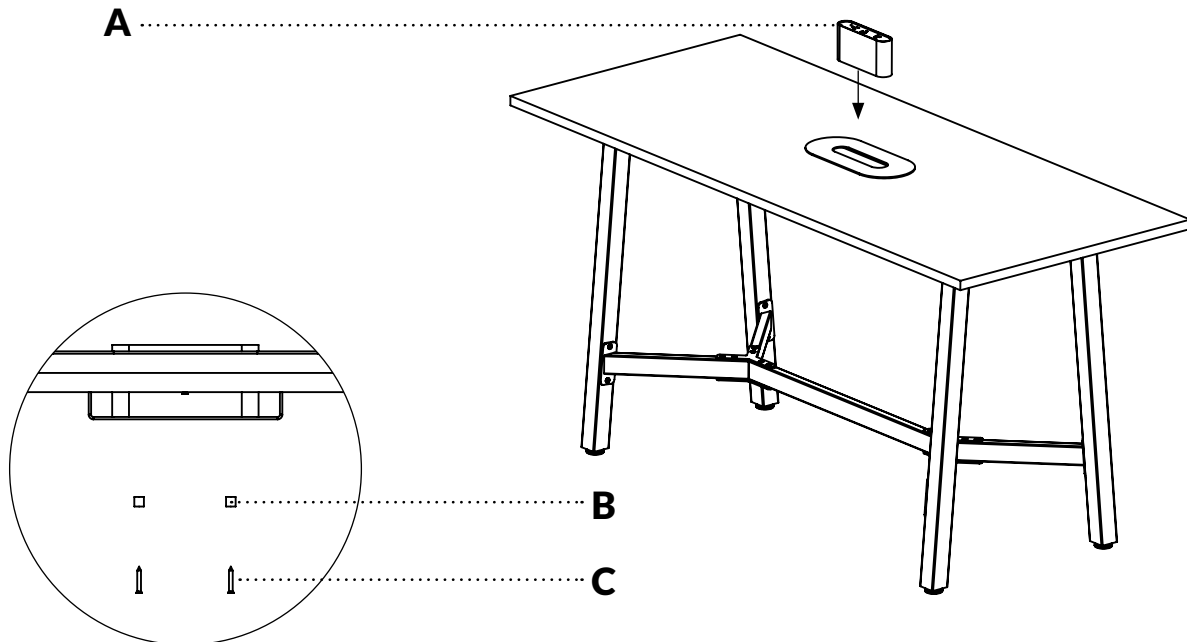

A 1 x electrical module



B 2 x black plastic washer



C 2 x screws included with electrical module